

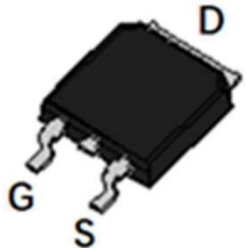
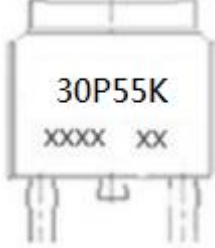
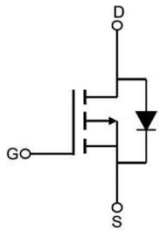

### Description

<b>Features</b> <ul style="list-style-type: none"> <li>➤ <math>V_{DS} = -30V</math>, <math>I_D = -40A</math>  <math>R_{DS(ON)} &lt; 11m\Omega @ V_{GS} = -10V</math>  <math>R_{DS(ON)} &lt; 16m\Omega @ V_{GS} = -4.5V</math></li> <li>➤ Advanced Trench Technology</li> <li>➤ Excellent <math>R_{DS(ON)}</math> and Low Gate Charge</li> <li>➤ Lead free product is acquired</li> </ul>	<b>Application</b> <ul style="list-style-type: none"> <li>➤ PWM Applications</li> <li>➤ Load Switch</li> <li>➤ Power Management</li> </ul> <p style="text-align: center;">100% UIS TESTED! 100% <math>\Delta V_{ds}</math> TESTED!</p>	
 TO-252(DPAK) top view	 Marking and pin Assignment	 Schematic Diagram

### Absolute Maximum Ratings ( $T_C=25^\circ C$ unless otherwise specified)

Symbol	Parameter	Max.	Unit
$V_{DSS}$	Drain-Source Voltage	-30	V
$V_{GSS}$	Gate-Source Voltage	$\pm 20$	V
$I_D$	Continuous Drain Current	$T_C = 25^\circ C$	-40
		$T_C = 100^\circ C$	-26
$I_{DM}$	Pulsed Drain Current <sup>note1</sup>	-134	A
$E_{AS}$	Single Pulsed Avalanche Energy <sup>note2</sup>	98	mJ
$P_D$	Power Dissipation	$T_C = 25^\circ C$	24.8
$R_{\theta JC}$	Thermal Resistance, Junction to Case	4.9	$^\circ C/W$
$T_J, T_{STG}$	Operating and Storage Temperature Range	-55 to +150	$^\circ C$



#### Electrical Characteristics (T<sub>J</sub>=25 °C unless otherwise specified)

Symbol	Parameter	Test Condition	Min.	Typ.	Max.	Unit
<b>Off Characteristic</b>						
V <sub>(BR)DSS</sub>	Drain-Source Breakdown Voltage	V <sub>GS</sub> =0V, I <sub>D</sub> = -250μA	-30	-	-	V
I <sub>DSS</sub>	Zero Gate Voltage Drain Current	V <sub>DS</sub> = -30V, V <sub>GS</sub> =0V	-	-	-1	μA
I <sub>GSS</sub>	Gate to Body Leakage Current	V <sub>DS</sub> =0V, V <sub>GS</sub> = ±20V	-	-	±100	nA
<b>On Characteristics</b>						
V <sub>GS(th)</sub>	Gate Threshold Voltage	V <sub>DS</sub> =V <sub>GS</sub> , I <sub>D</sub> = -250μA	-1.0	-1.6	-2.5	V
R <sub>DS(on)</sub>	Static Drain-Source on-Resistance <small>note3</small>	V <sub>GS</sub> = -10V, I <sub>D</sub> = -20A	-	8.5	11	mΩ
		V <sub>GS</sub> = -4.5V, I <sub>D</sub> = -10A	-	12.0	16	
<b>Dynamic Characteristics</b>						
C <sub>iss</sub>	Input Capacitance	V <sub>DS</sub> = -15V, V <sub>GS</sub> =0V, f=1.0MHz	-	3564	-	pF
C <sub>oss</sub>	Output Capacitance		-	416	-	pF
C <sub>rss</sub>	Reverse Transfer Capacitance		-	373	-	pF
Q <sub>g</sub>	Total Gate Charge	V <sub>DS</sub> = -15V, I <sub>D</sub> = -20A, V <sub>GS</sub> = -10V	-	37	-	nC
Q <sub>gs</sub>	Gate-Source Charge		-	6.5	-	nC
Q <sub>gd</sub>	Gate-Drain("Miller") Charge		-	9.4	-	nC
<b>Switching Characteristics</b>						
t <sub>d(on)</sub>	Turn-on Delay Time	V <sub>DD</sub> = -15V, I <sub>D</sub> = -20A, V <sub>GS</sub> = -10V, R <sub>GEN</sub> =2.5Ω	-	16	-	ns
t <sub>r</sub>	Turn-on Rise Time		-	21	-	ns
t <sub>d(off)</sub>	Turn-off Delay Time		-	68	-	ns
t <sub>f</sub>	Turn-off Fall Time		-	52	-	ns
<b>Drain-Source Diode Characteristics and Maximum Ratings</b>						
I <sub>S</sub>	Maximum Continuous Drain to Source Diode Forward Current		-	-	-40	A
I <sub>SM</sub>	Maximum Pulsed Drain to Source Diode Forward Current		-	-	-134	A
V <sub>SD</sub>	Drain to Source Diode Forward Voltage	V <sub>GS</sub> =0V, I <sub>S</sub> = -30A	-	-0.8	-1.2	V

Notes: 1. Repetitive Rating: Pulse Width Limited by Maximum Junction Temperature

2. EAS condition: T<sub>J</sub>= 25 °C, V<sub>DD</sub>= -15V, V<sub>G</sub>= -10V, L= 0.5mH, R<sub>G</sub>= 25Ω, I<sub>AS</sub>= -20A

3. Pulse Test: Pulse Width≤300μs, Duty Cycle≤2%



### Typical Performance Characteristics

Figure 1: Output Characteristics

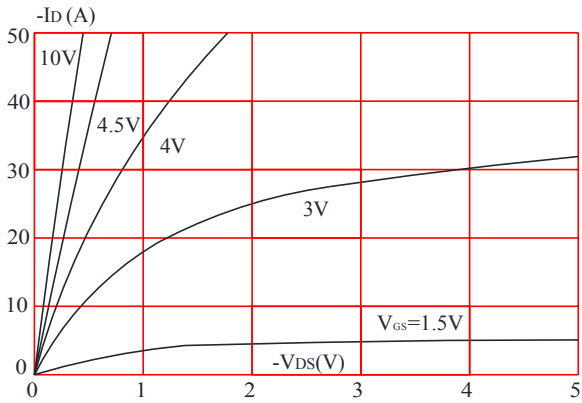

Figure 2: Typical Transfer Characteristics

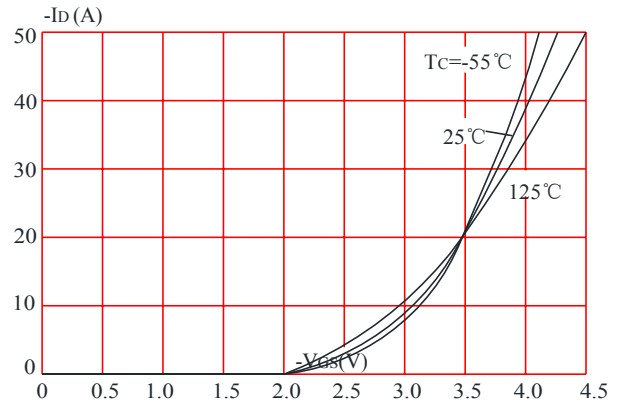

Figure 3: On-resistance vs. Drain Current

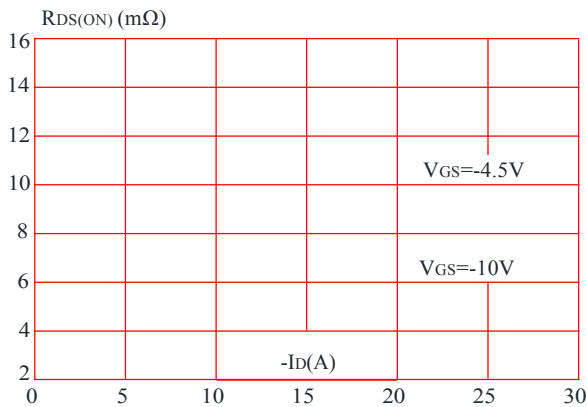

Figure 4: Body Diode Characteristics

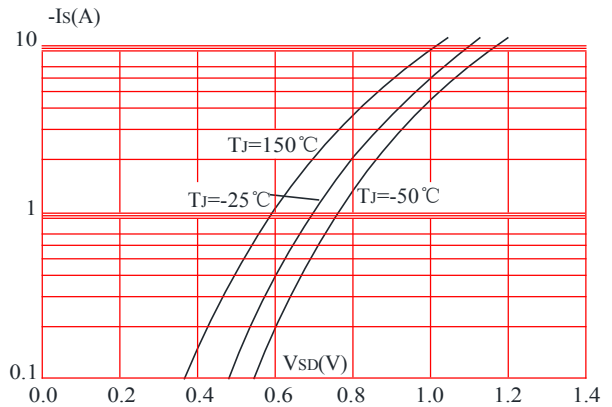

Figure 5: Gate Charge Characteristics

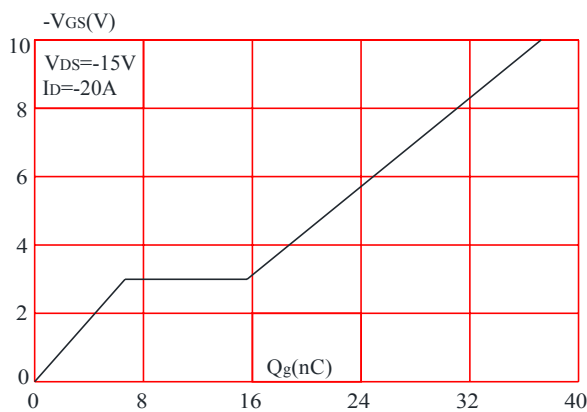

Figure 6: Capacitance Characteristics

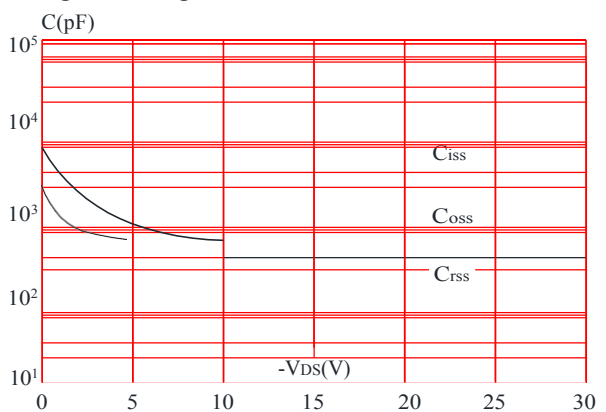



Figure 7: Normalized Breakdown Voltage vs. Junction Temperature

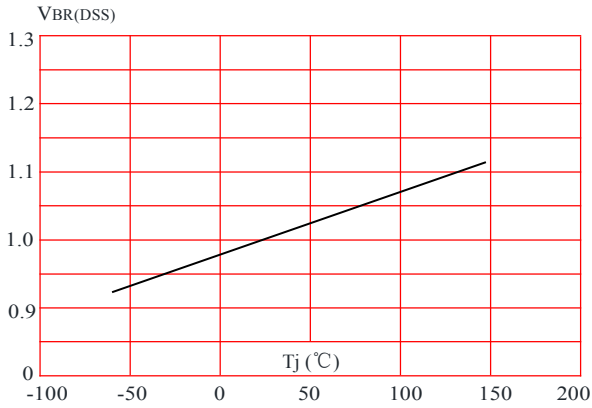

Figure 8: Normalized on Resistance vs. Junction Temperature

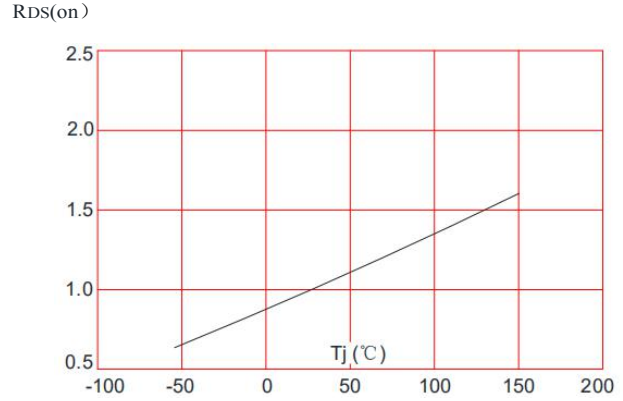

Figure 9: Maximum Safe Operating Area

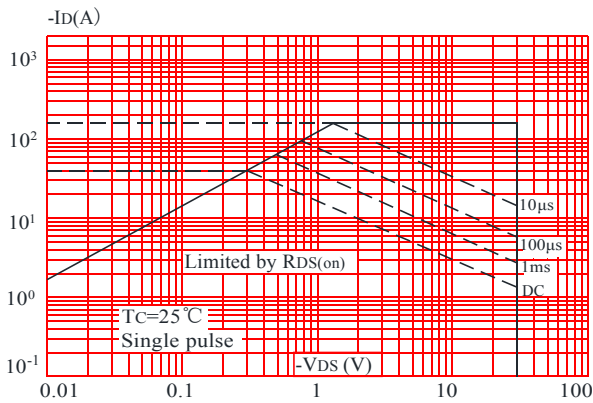

Figure 10: Maximum Continuous Drain Current vs. Case Temperature

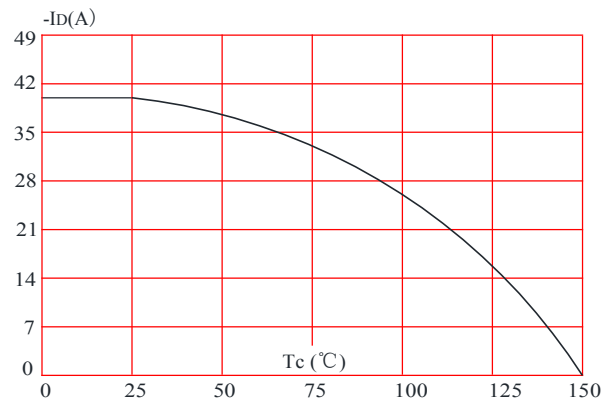
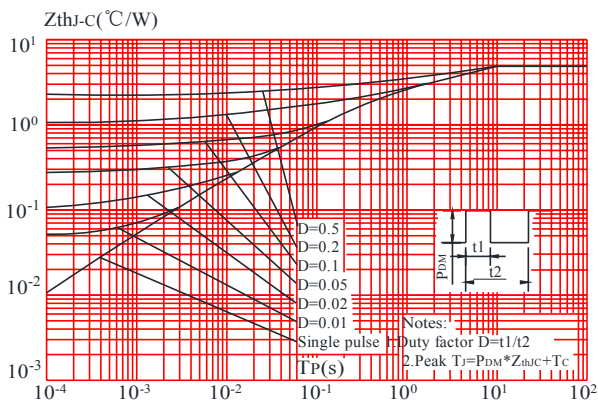

Figure.11: Maximum Effective Transient Thermal Impedance, Junction-to-Case





#### Test Circuit

##### Gate Charge Test Circuit & Waveform

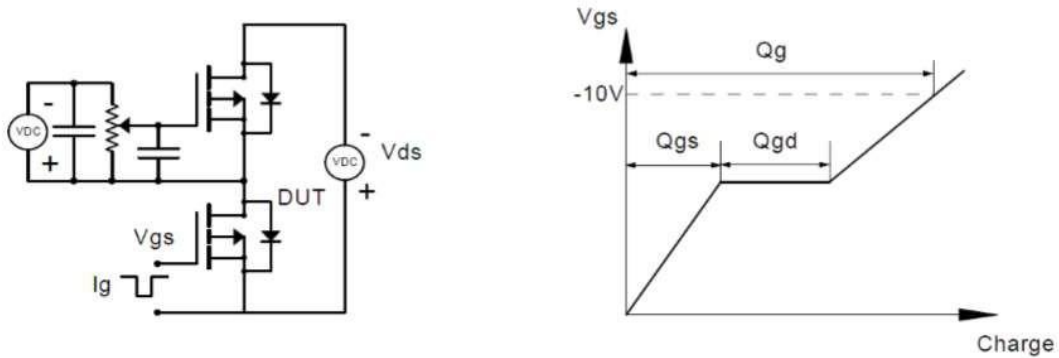

##### Resistive Switching Test Circuit & Waveforms

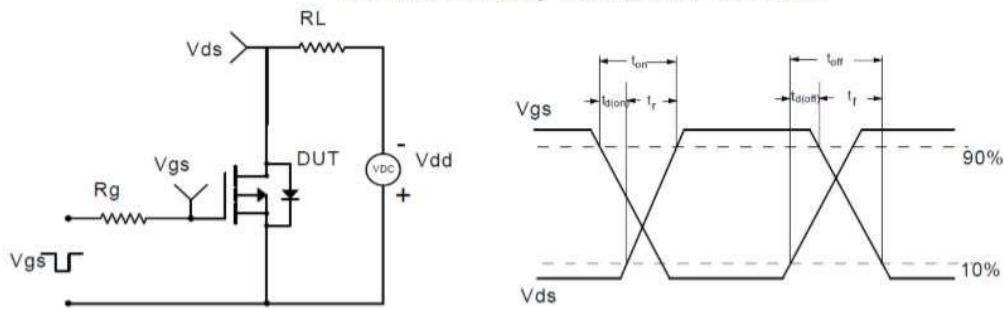

##### Unclamped Inductive Switching (UIS) Test Circuit & Waveforms

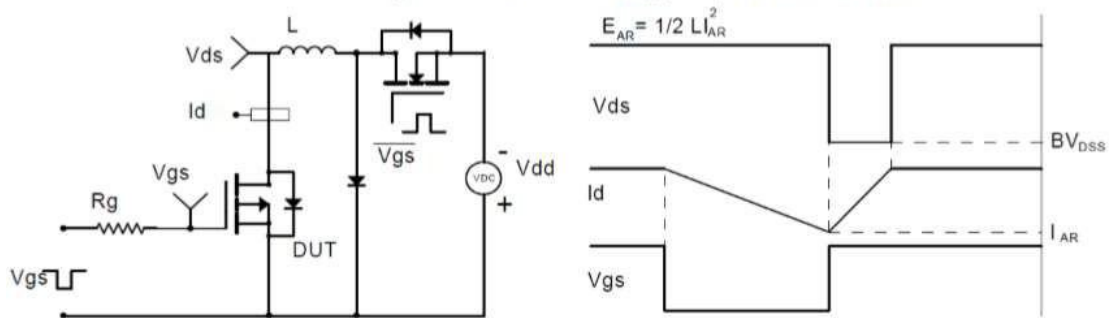

##### Diode Recovery Test Circuit & Waveforms

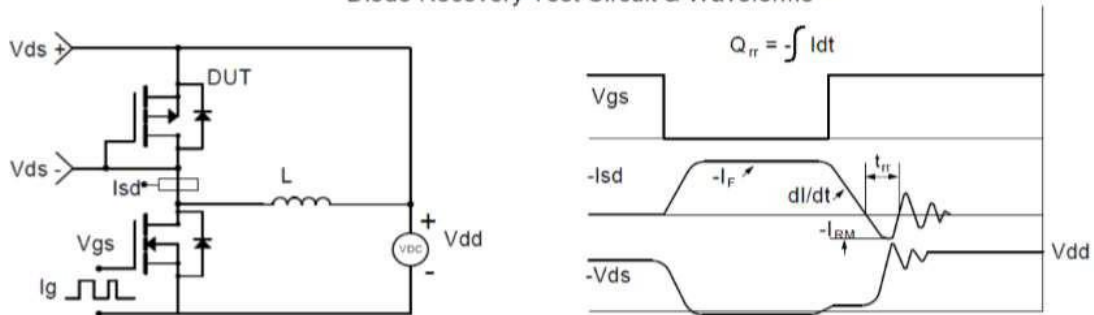



### TO-252 Package Information

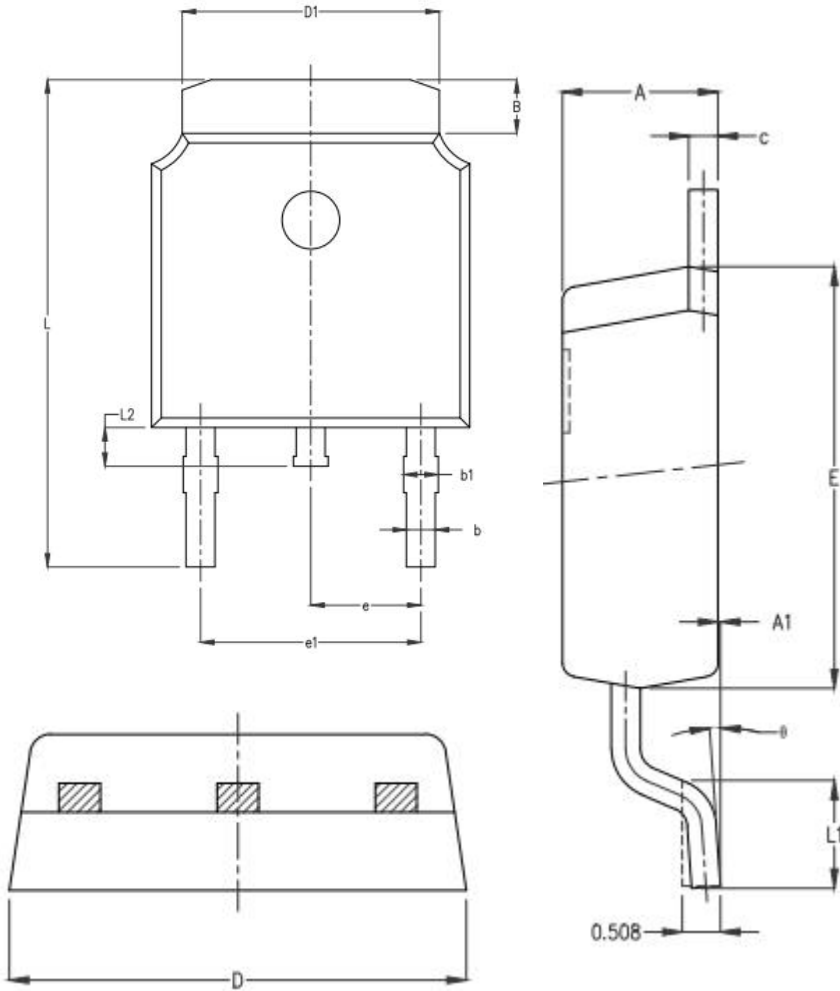

SYMBOL	MILLIMETER		
	MIN	NOM	MAX
A	2.15	2.25	2.35
A1	0.00	0.06	0.12
B	0.96	1.11	1.26
b	0.59	0.69	0.79
b1	0.69	0.81	0.93
c	0.34	0.42	0.50
D	6.45	6.60	6.75
D1	5.23	5.33	5.43
E	5.95	6.10	6.25
e	2.286TYP.		
e1	4.47	4.57	4.67
L	9.90	10.10	10.30
L1	1.40	1.55	1.70
L2	0.60	0.80	1.00
θ	0°	4°	8°