



80H11D(文件编号: S&CIC1707)

N-Channel Trench Power MOSFET

Features

- VDS=80V; ID=110A@ VGS=10V;
RDS(ON)<6.8mΩ @ VGS=10V
- Special Designed for E-Bike Controller Application
- Ultra Low On-Resistance
- High UIS and UIS 100% Test

Application

- 64V E-Bike Controller Applications
- Hard Switched and High Frequency Circuits
- Uninterruptible Power Supply

Package

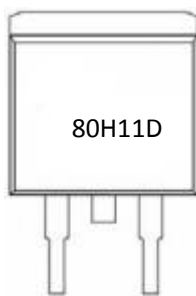

Marking and pin assignment

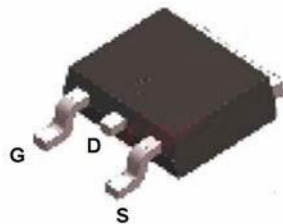

TO-263top view

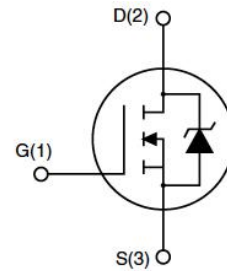

Schematic diagram

Package Marking and Ordering Information

Device Marking	Device	Device Package	Reel Size	Tape width	Quantity
80H11D	80H11D	TO-263	-	-	-

Table 1. Absolute Maximum Ratings (TA=25°C)

Symbol	Parameter	Value	Unit
V _{DS}	Drain-Source Voltage (V _{GS} =0V)	80	V
V _{GS}	Gate-Source Voltage (V _{DS} =0V)	±20	V
I _{D(DC)}	Drain Current (DC) at Tc=25°C	110	A
I _{D(DC)}	Drain Current (DC) at Tc=100°C	80	A
I _{DM (pluse)}	Drain Current-Continuous@ Current-Pulsed (Note 1)	450	A
dv/dt	Peak Diode Recovery Voltage	7.1	V/ns
P _D	Maximum Power Dissipation(Tc=25°C)	208	W
	Derating Factor	1.45	W/°C
E _{AS}	Single Pulse Avalanche Energy (Note 2)	688	mJ
T _J , T _{STG}	Operating Junction and Storage Temperature Range	-55 To 175	°C

Notes: 1. Repetitive Rating: Pulse width limited by maximum junction temperature

2. EAS condition: T_J=25°C, V_{DD}=40V, V_G=10V, R_G=25 Ω



Table 2. Thermal Characteristic

Symbol	Parameter	Value	Max	Unit
$R_{\theta JC}$	Thermal Resistance, Junction-to-Case	---	0.8	$^{\circ}C/W$

Table 3. Electrical Characteristics (TA=25°C unless otherwise noted)

Symbol	Parameter	Conditions	Min	Typ	Max	Unit
On/Off States						
BV_{DSS}	Drain-Source Breakdown Voltage	$V_{GS}=0V, I_D=250\mu A$	80			V
I_{DSS}	Zero Gate Voltage Drain Current (Tc=25°C)	$V_{DS}=78V, V_{GS}=0V$			1	μA
I_{DSS}	Zero Gate Voltage Drain Current (Tc=125°C)	$V_{DS}=75V, V_{GS}=0V$			10	μA
I_{GSS}	Gate-Body Leakage Current	$V_{GS}=\pm 20V, V_{DS}=0V$			± 100	nA
$V_{GS(th)}$	Gate Threshold Voltage	$V_{DS}=V_{GS}, I_D=250\mu A$	2		4	V
$R_{DS(ON)}$	Drain-Source On-State Resistance	$V_{GS}=10V, I_D=40A$		5.8	6.8	m Ω
Dynamic Characteristics						
g_{FS}	Forward Transconductance	$V_{DS}=10V, I_D=15A$	25			S
C_{iss}	Input Capacitance	$V_{DS}=25V, V_{GS}=0V, f=1.0MHz$		7190		PF
C_{oss}	Output Capacitance			463		PF
C_{rss}	Reverse Transfer Capacitance			284		PF
Q_g	Total Gate Charge	$V_{DS}=50V, I_D=40A, V_{GS}=10V$		139		nC
Q_{gs}	Gate-Source Charge			26		nC
Q_{gd}	Gate-Drain Charge			51		nC
Switching Times						
$t_{d(on)}$	Turn-on Delay Time	$V_{DD}=30V, I_D=40A, R_L=15\Omega, V_{GS}=10V, R_G=2.5\Omega$		30		nS
t_r	Turn-on Rise Time			50		nS
$t_{d(off)}$	Turn-Off Delay Time			79		nS
t_f	Turn-Off Fall Time			23		nS
Source-Drain Diode Characteristics						
I_{SD}	Source-drain Current (Body Diode)			110		A
I_{SDM}	Pulsed Source-Drain Current (Body Diode)			450		A
V_{SD}	Forward On Voltage <small>(NOTE 1)</small>	$T_J=25^{\circ}C, I_{SD}=40A, V_{GS}=0V$		0.87	0.99	V
t_{rr}	Reverse Recovery Time <small>(NOTE 1)</small>	$T_J=25^{\circ}C, I_F=75A, di/dt=100A/\mu s$		36		nS
Q_{rr}	Reverse Recovery Charge <small>(NOTE 1)</small>			63		nC
t_{on}	Forward Turn-on Time	Intrinsic turn-on time is negligible (turn-on is dominated by L_S+L_D)				

Notes 1. Pulse Test: Pulse Width $\leq 300\mu s$, Duty Cycle $\leq 1.5\%$, $R_G=25\Omega$, Starting $T_J=25^{\circ}C$

Test Circuit

1) E_{AS} Test Circuits

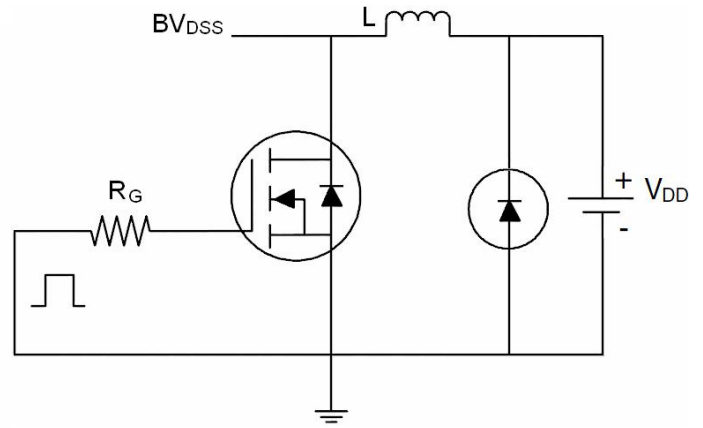
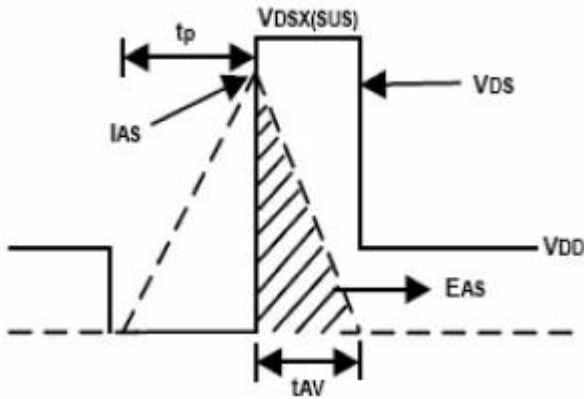

2) Gate Charge Test Circuit:

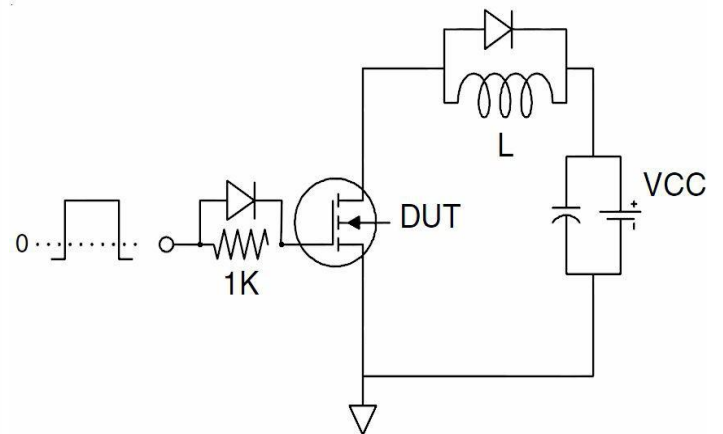
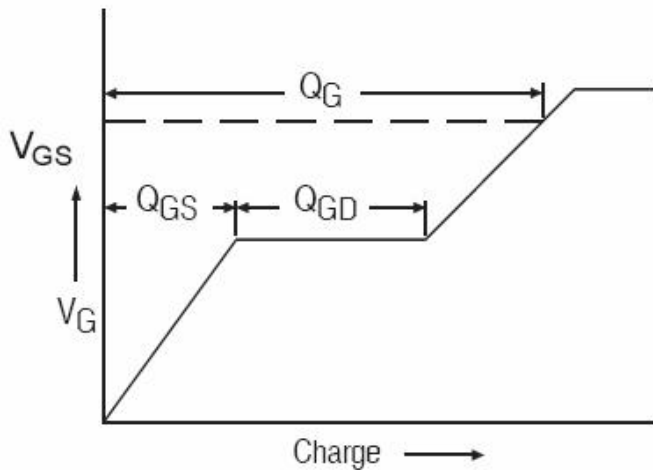

3) Switch Time Test Circuit:

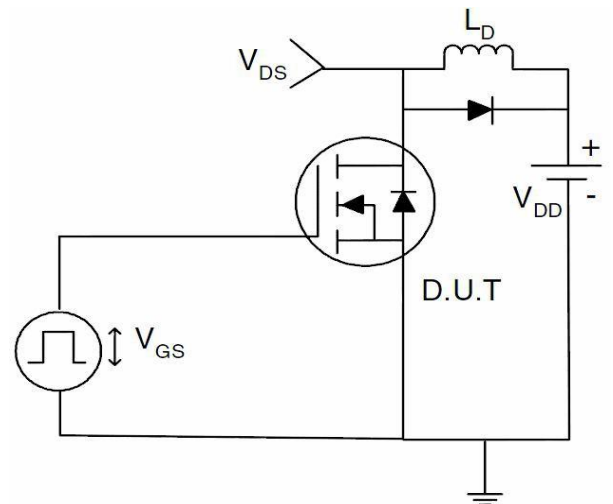
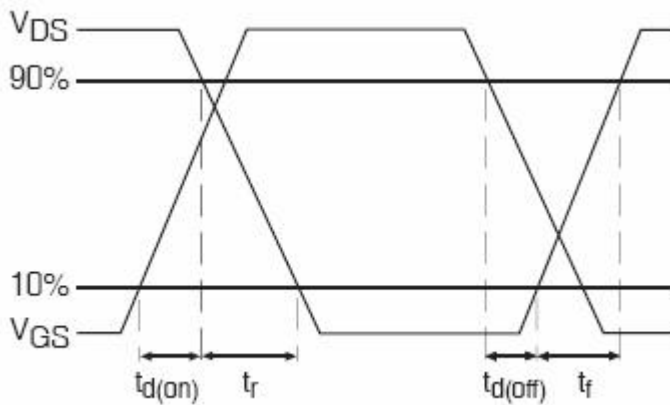



TYPICAL ELECTRICAL AND THERMAL CHARACTERISTICS (Curves)

Figure1. Output Characteristics

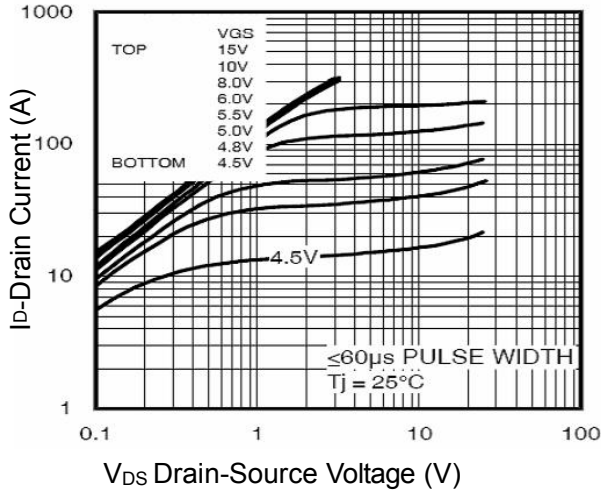

Figure2. Transfer Characteristics

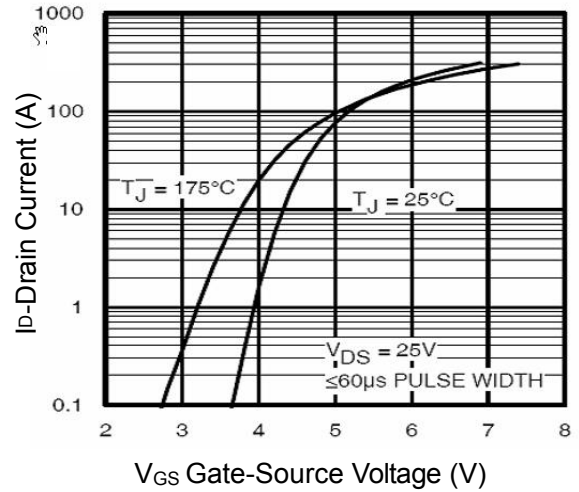

Figure3. ID vs Junction Temperature

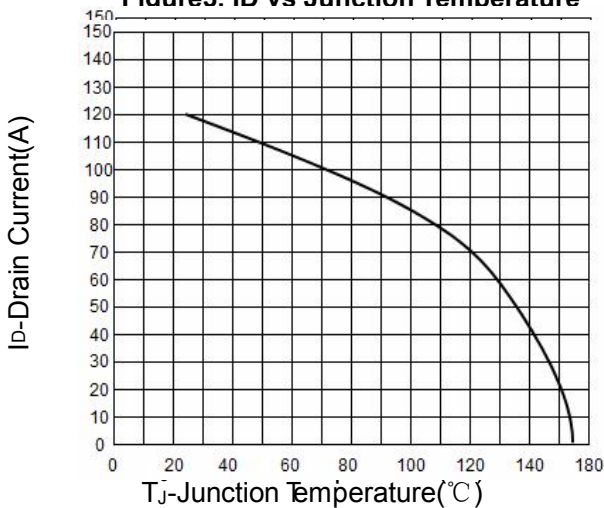

Figure4. Rds(on) Vs Junction Temperature

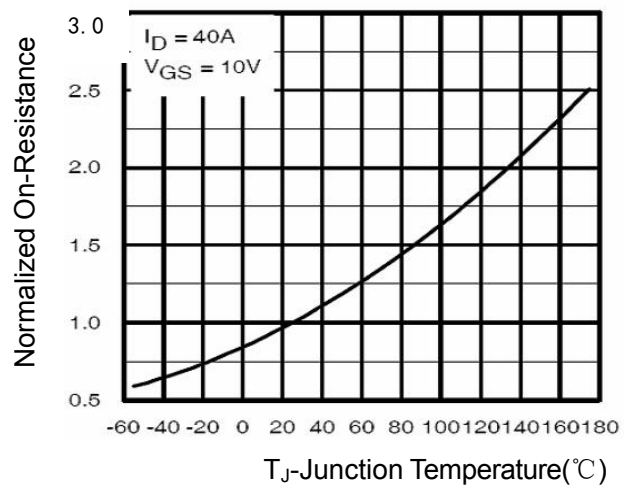

Figure5. BVDS vs Junction Temperature

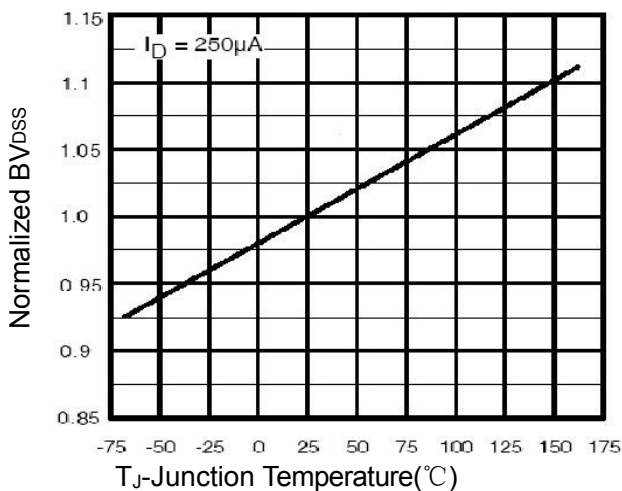

Figure6. VGS(th) vs Junction Temperature

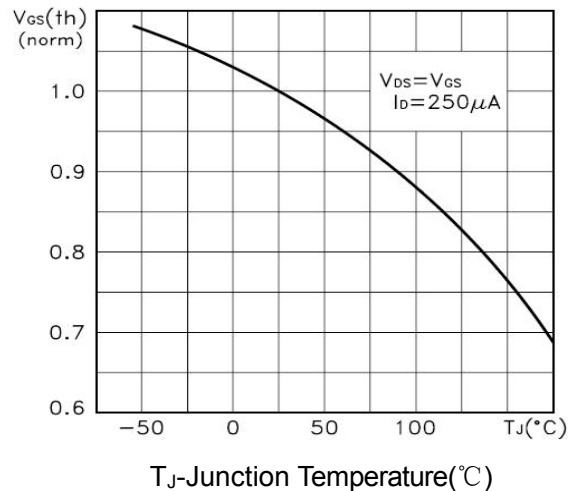



Figure7. Gate Charge

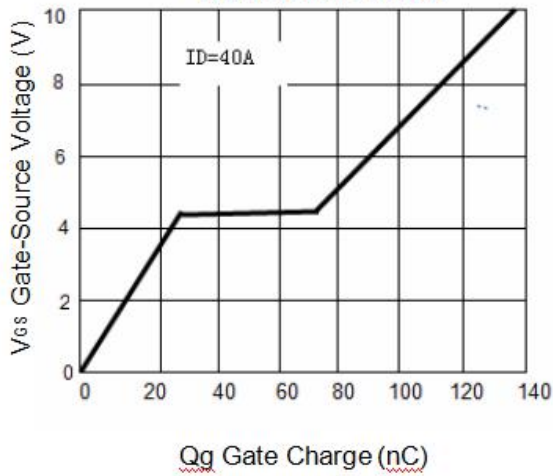

Figure8. Capacitance vs Vds

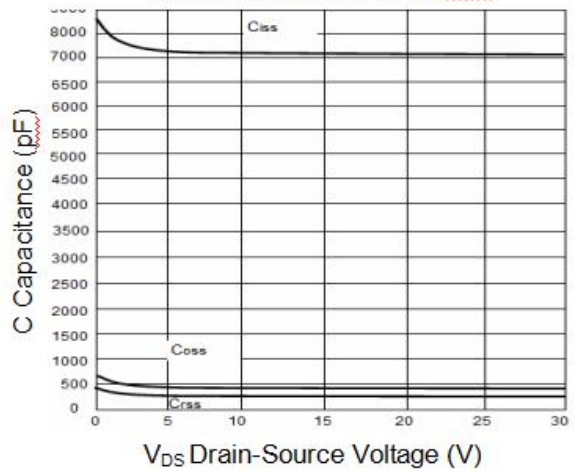

Figure9. Source- Drain Diode Forward

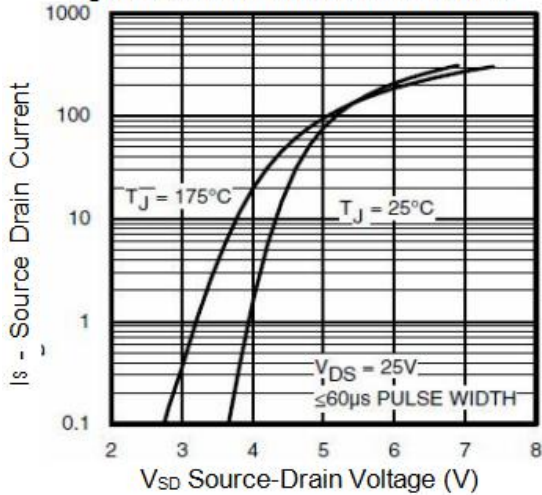

Figure10. Safe Operation Area

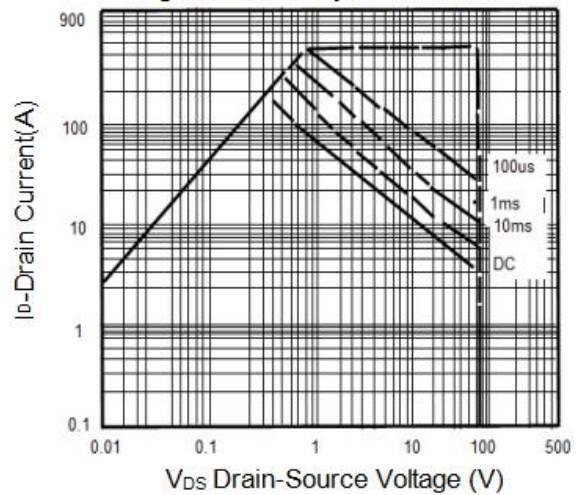
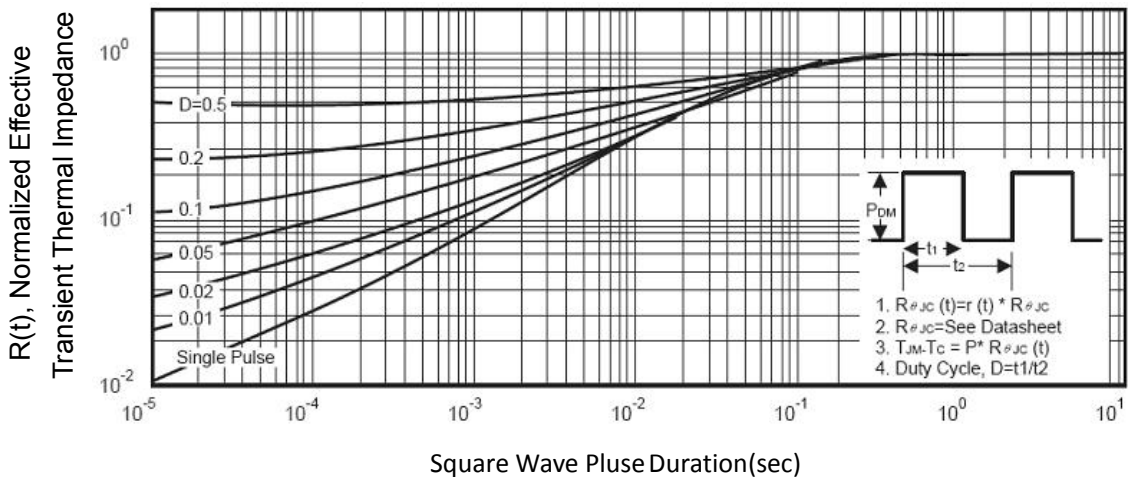
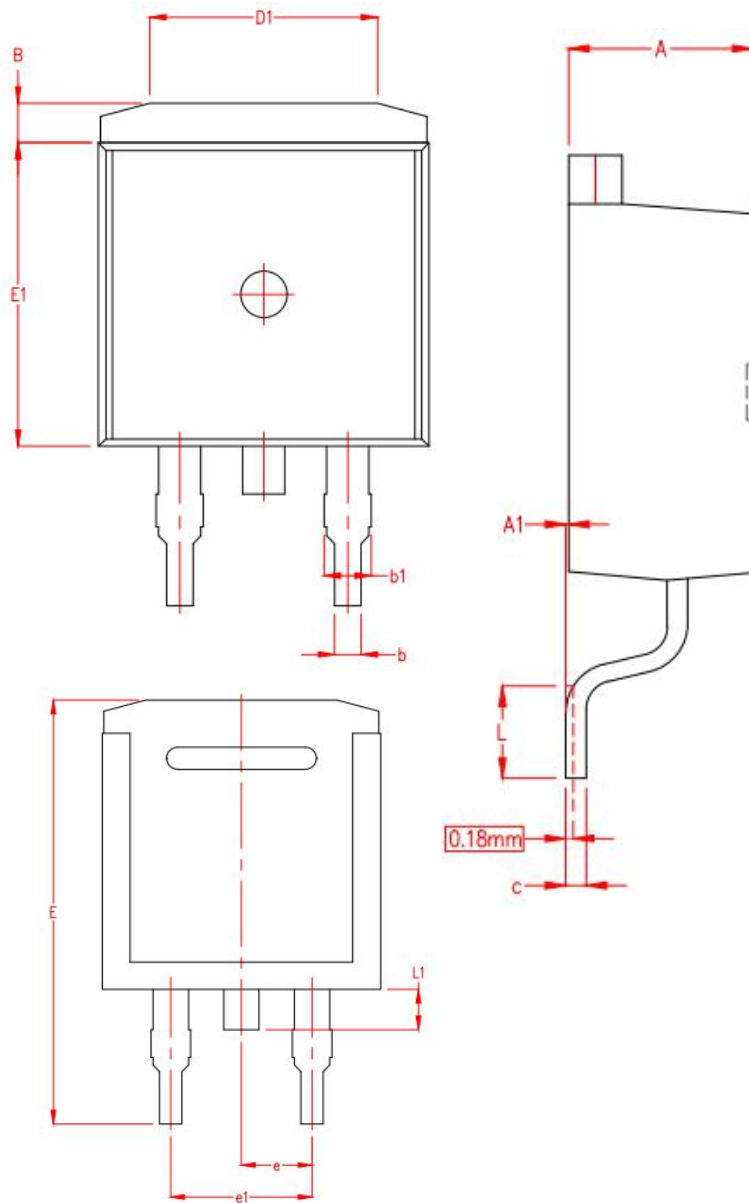

Figure11. Normalized Maximum Transient Thermal Impedance





TO-263 Package Information



SYMBOL	MILLIMETER		
	MIN	NOM	MAX
A	4.45	4.50	4.55
A1	0	0.07	0.15
B	1.08	1.20	1.32
b	0.80TYP.		
b1	1.24	1.27	1.30
c	0.48	0.50	0.52
D	9.95	10.00	10.05
D1	6.89REF.		
E	15.09	15.24	15.39
E1	9.15	9.20	9.25
e	2.51	2.54	2.57
e1	5.05	5.08	5.11
L	2.29	2.54	2.79